

ASSEMBLY INSTRUCTION

MODEL: F14-2677

SIZE: 2600x770x1100H

ASSEMBLY TIPS:

1. Remove hardware from box and sort by size
2. Please check all hardware and parts are present prior to the start of assembly.
3. Please follow the attached instructions in the same sequence as numbered to assure the fast & easy assembly.

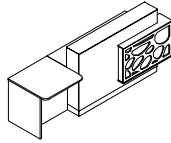

PARTS IDENTIFICATION:

NO	Q' TY
1	1PCS
2	1PCS
3	1PCS
4	1PCS
5	1PCS
6	2PCS
7	1PCS
8	1PCS
9	4PCS
10	3PCS
11	2PCS
12	1PCS
13	1PCS
14	1PCS

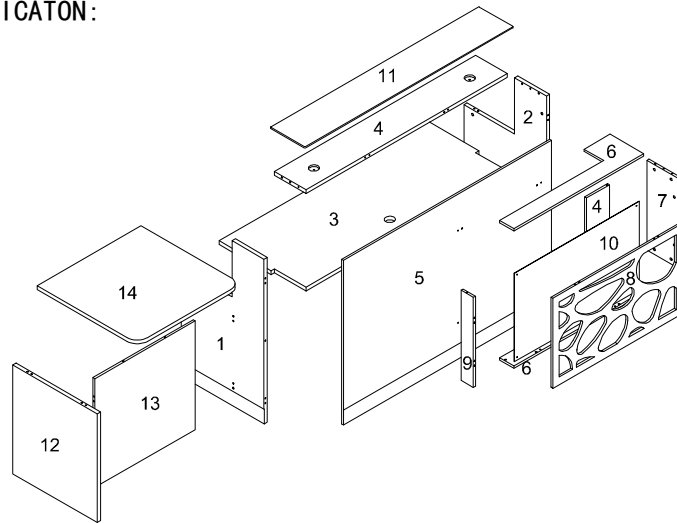

HARDWARE PACKAGE:

NO	SIZE	FIGURE	Q' TY	NO	SIZE	FIGURE	Q' TY
A	Ø15		38PCS				
B	L=34		38PCS				
C	Ø8x30		34PCS				
D			1PCS				
E	M4x14		12PCS				
F	M4x35		4PCS				
G			2PCS				
H			1PCS				
I	Ø60		2PCS				
	M6x20		2PCS				

ASSEMBLY INSTRUCTION

MODEL: F14-2677

SIZE: 2600x770x1100H

STEP1

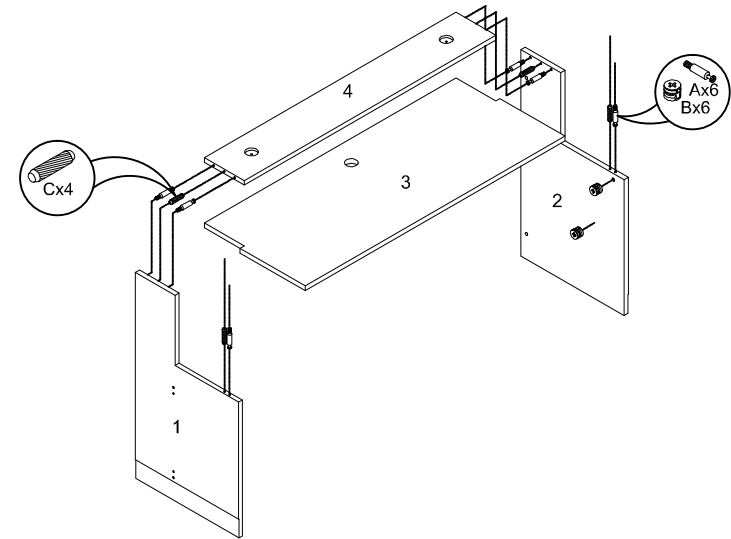

STEP2

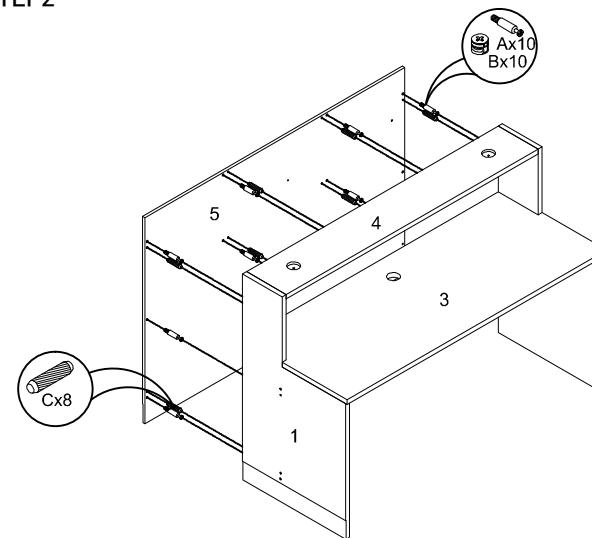

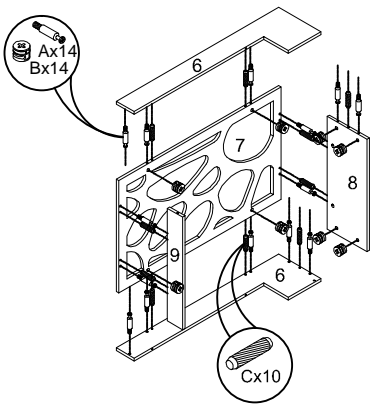
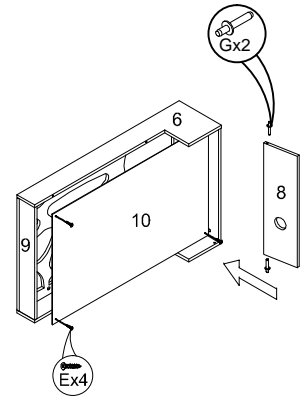
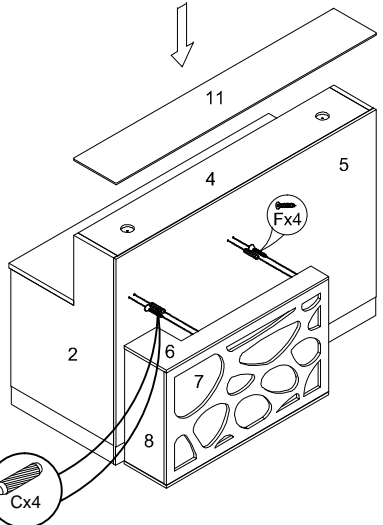
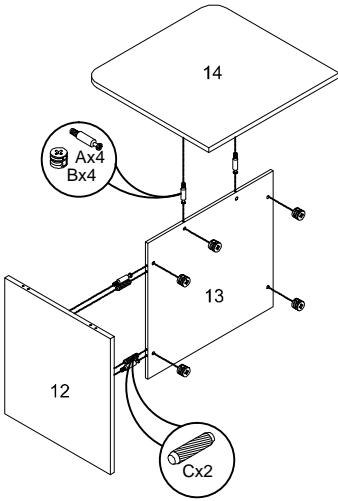
ASSEMBLY INSTRUCTION	
MODEL: F14-2677	SIZE: 2600x770x1100H
<p style="text-align: center; margin-bottom: 10px;">STEP3</p> 	<p style="text-align: center; margin-bottom: 10px;">STEP4</p> 
<p style="text-align: center; margin-bottom: 10px;">STEP5</p> 	<p style="text-align: center; margin-bottom: 10px;">STEP6</p> 

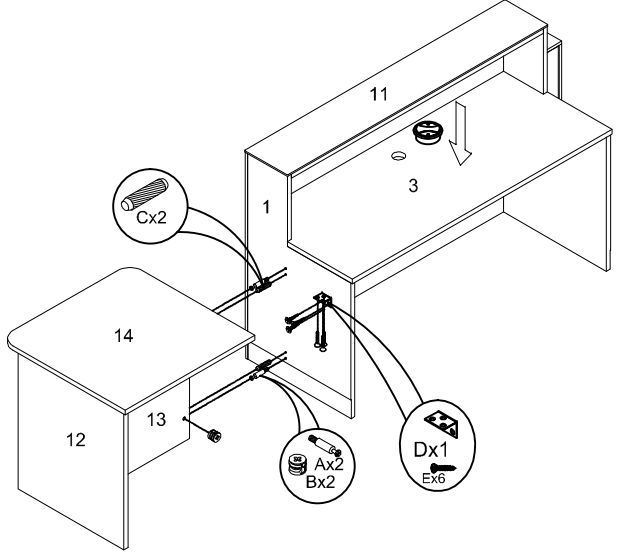
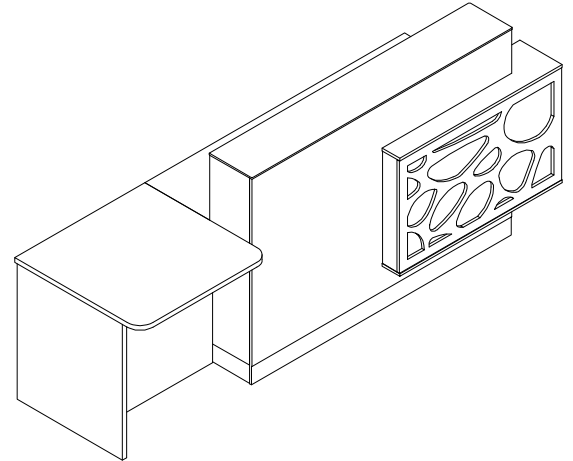
ASSEMBLY INSTRUCTION	
MODEL: F14-2677	SIZE: 2600x770x1100H
<p style="text-align: center; margin-bottom: 10px;">STEP7</p> 	
<p style="text-align: center; margin-bottom: 10px;">STEP8</p> 	

ASSEMBLY INSTRUCTION

MODEL: FR- SIZE: 400x450x600H

ASSEMBLY TIPS:

- 1.Remove hardware from box and sort by size
- 2.Please check all hardware and parts are present prior to the start of assembly.
- 3.Please follow the attached instructions in the same sequence as numbered to assure the fast & easy assembly.



PARTS IDENTIFICATION:

NO	Q'TY
1	1PCS
2	1PCS
3	1PCS
4	1PCS
5	1PCS
6	1PCS
7	2PCS
8	2PCS
9	1PCS
10	1PCS
11	2PCS
12	1PCS

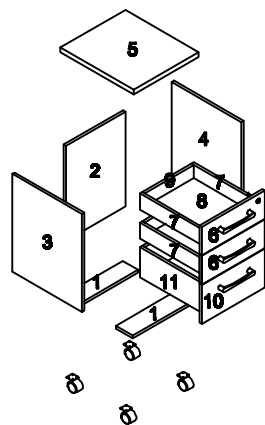

HARDWARE PACKAGE:

NO	SIZE	FIGURE	Q'TY	NO	SIZE	FIGURE	QTY
A	Ø15		21PCS				
B	L=34		21PCS				
C	Ø6x30		8PCS				
D	14寸		2PCS				
E	M4x14		58PCS				
F	M4x35		8PCS				
G			2PCS				
H	450L		1PCS				
I	M4x18		4PCS				
J			2PCS				
K			4PCS				
L							
M							

ASSEMBLY INSTRUCTION

MODEL: FR- SIZE: 400x450x600H

STEP1

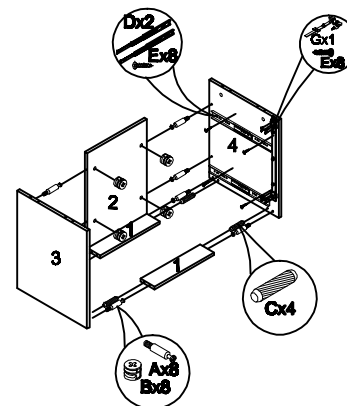

STEP2

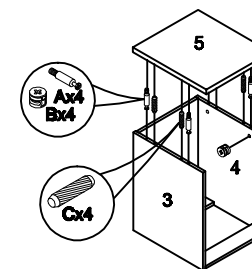

STEP3

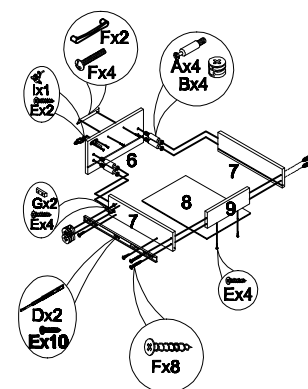

STEP4

